

7SG14 Duobias-M

Transformer Protection

Document Release History

This document is issue 2010/02. The list of revisions up to and including this issue is:
Pre release

2010/02	Document reformat due to rebrand
25/09/2006	R4 Reformatted to match other manual sections
08/04/2005	R3 Corrected, now 8 settings groups
10/02/2005	R2 Added missing Select Grp Mode setting
31/01/2005	R1 First Issue

Software Revision History

--	--	--

The copyright and other intellectual property rights in this document, and in any model or article produced from it (and including any registered or unregistered design rights) are the property of Siemens Protection Devices Limited. No part of this document shall be reproduced or modified or stored in another form, in any data retrieval system, without the permission of Siemens Protection Devices Limited, nor shall any model or article be reproduced from this document unless Siemens Protection Devices Limited consent.

While the information and guidance given in this document is believed to be correct, no liability shall be accepted for any loss or damage caused by any error or omission, whether such error or omission is the result of negligence or any other cause. Any and all such liability is disclaimed.

Contents

1	INTRODUCTION	3
2	DUOBIAS-M-208-5W RELAY SETTING LIST	4
2.1	SYSTEM CONFIG MENU	4
2.2	CT/VT CONFIG MENU	4
2.3	BIASED DIFFERENTIAL MENU	5
2.4	RESTRICTED E/F 1 MENU	7
2.5	RESTRICTED E/F 2 MENU	7
2.6	RESTRICTED E/F 3 MENU	7
2.7	STANDBY E/F MENU	7
2.8	VOLTAGE MENU	8
2.9	FREQUENCY MENU	9
2.10	OVERFLUXING MENU	11
2.11	STATUS INPUT MENU	12
2.12	REYLOGIC CONTROL MENU	14
2.13	REYLOGIC ELEMENT MENU	14
2.14	OUTPUT RELAY MENU	14
2.15	OP RELAY TIMING MENU	16
2.16	LED MENU	16
2.17	DATA STORAGE MENU	18
2.18	COMMUNICATIONS MENU	18
3	INSTRUMENTS	20
4	IEC 60870-5-103 COMMUNICATIONS INFORMATION	23
4.1	IEC 60870-5-103 Semantics in monitor direction	23
4.2	IEC 60870-5-103 Semantics in control direction	26
5	MODBUS SEMANTICS	27
5.1	COILS (0xxxx)	27
5.2	INPUT STATUS (1xxxx)	27
5.3	INPUT REGISTERS (3xxxx)	29
5.4	HOLDING REGISTERS (4xxxx)	31
6	REYLOGIC DIAGRAMS	32
7	LABEL INSERTS	36
7.1	5W E16 CASE	36

Figures

Figure 1 - Duobias-M-208-5W [DU3-508]	3
---------------------------------------	---

1 Introduction

This relay settings section covers the following Duobias-M models:-

Model No
Duobias-M-208-5W-STD-50Hz

Cat No
DU3-x07-**-50

Configuration No
2661H80059R14

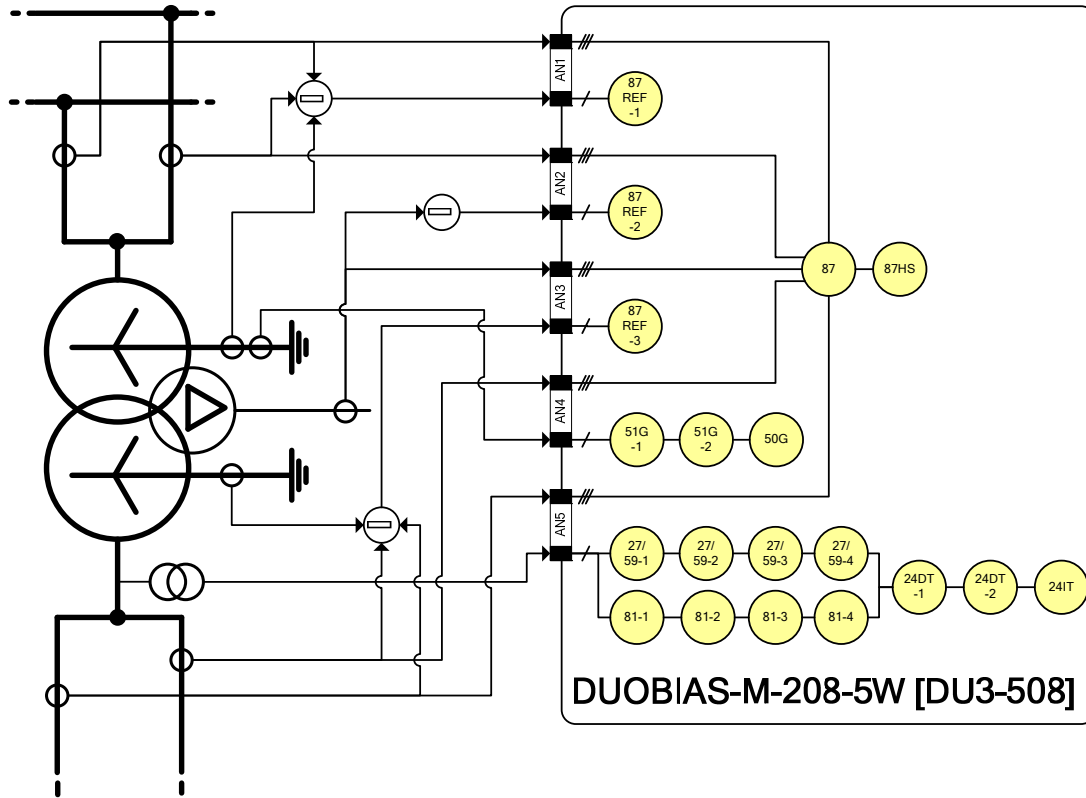

Figure 1 - Duobias-M-208-5W [DU3-508]

2 DUOBIAS-M-208-5W Relay Setting List

2.1 System Config Menu

Description	Range	Default	Setting
Active Group <i>Selects which settings group is currently activated</i>	1,2...8	1	
View/Edit Group <i>Selects which settings group is currently being displayed</i>	1,2...8	1	
Default Screens Timer <i>Selects the time delay after which, if no key presses have been detected, the relay will begin to poll through any screens which have been selected as default instruments screens</i>	OFF, 1,2,5,10,15,30,60 min	60 min	
Backlight timer <i>Controls when the LCD backlight turns off</i>	OFF, 1,2,5,10,15,30,60 min	5 Min	
Date	Date	1/1/1980	
Time	Time	00:00:00	
Select Grp Mode <i>Mode of operation of group change from status input. Edge triggered ignores the status input once it has changed to the relevant group, where as with Level triggered the relay will only stay in the group it has changed to whilst the status input is being driven, after which it returns to the previous group.</i>	Edge triggered, Level triggered	Edge triggered	
Clock Sync. From Status <i>Real time clock may be synchronised using a status input (See Clock Sync. in Status Input Menu)</i>	Disabled, Seconds,Minutes	Minutes	
Operating Mode <i>To allow access to change configuration files using Reylogic Toolbox the relay must be placed Out Of Service.</i>	Local, Remote, Local Or Remote, Out Of Service	Local Or Remote	
Change Password <i>Allows a 4 character alphanumeric code to be entered as the password. Note that the display shows a password dependant encrypted code on the second line of the display</i>	AAAA...ZZZZ	"NONE" displayed as "NOT ACTIVE"	
Relay Identifier <i>An alphanumeric string shown on the LCD normally used to identifier the circuit the relay is attached to or the relays purpose</i>	Up to 16 characters	DUOBIAS-M-208-5W	

2.2 CT/VT Config Menu

Description	Range	Default	Setting
W1 Input <i>Selects whether 1 or 5 Amp terminals are being used for winding 1</i>	1,5 A	1 A	
W1 CT Ratio <i>Winding 1 CT ratio to scale primary current instruments</i>	5:0.2...5000:7	2000:1	
W2 Input <i>Selects whether 1 or 5 Amp terminals are being used for winding 2</i>	1,5 A	1 A	
W2 CT Ratio <i>Winding 1 CT ratio to scale primary</i>	5:0.2...5000:7	2000:1	

Description	Range	Default	Setting
<i>current instruments</i>			
W3 Input <i>Selects whether 1 or 5 Amp terminals are being used for winding 3</i>	1,5 A	1 A	
W3 CT Ratio <i>Winding 3 CT ratio to scale primary current instruments</i>	5:0.2...5000:7	2000:1	
W4 Input <i>Selects whether 1 or 5 Amp terminals are being used for winding 4</i>	1,5 A	1 A	
W4 CT Ratio <i>Winding 4 CT ratio to scale primary current instruments</i>	5:0.2...5000:7	2000:1	
W5 Input <i>Selects whether 1 or 5 Amp terminals are being used for winding 5</i>	1,5 A	1 A	
W5 CT Ratio <i>Winding 5 CT ratio to scale primary current instruments</i>	5:0.2...5000:7	2000:1	
REF-1 Input <i>Selects whether 1 or 5 Amp terminals are being used for REF-1</i>	1,5 A	1 A	
REF-1 CT Ratio <i>REF-1 CT ratio to scale primary current instruments</i>	5:0.2...5000:7	2000:1	
REF-2 Input <i>Selects whether 1 or 5 Amp terminals are being used for REF-2</i>	1,5 A	1 A	
REF-2 CT Ratio <i>REF-2 CT ratio to scale primary current instruments</i>	5:0.2...5000:7	2000:1	
REF-3 Input <i>Selects whether 1 or 5 Amp terminals are being used for REF-3</i>	1,5 A	1 A	
REF-3 CT Ratio <i>REF-3 CT ratio to scale primary current instruments</i>	5:0.2...5000:7	2000:1	
E/F Input <i>Selects whether 1 or 5 Amp terminals are being used for the standby earth fault input</i>	1,5 A	1 A	
E/F CT Ratio <i>Earth fault CT ratio to scale primary current instruments</i>	5:0.2...5000:7	2000:1	
Nominal Voltage Vn <i>Selects the nominal voltage setting of the voltage input</i>	40,40.1...160 V	63.5 V	
VT Ratio <i>VT ratio to scale primary voltage instrument</i>	3300:40...1000000:160	132000:110	
VT Connection <i>Selects whether phase to neutral or phase to phase voltages are connected to the relay voltage input to scale the primary voltage instrument</i>	Vpn, Vpp	Vpn	

2.3 Biased Differential Menu

Description	Range	Default	Setting
W1 Interposing CT Multiplier <i>Winding 1 scaling factor</i>	0.25,0.26...3.00 x	1.00 x	
W1 Interposing CT Connection <i>Winding 1 transformer vector group compensation and/or zero sequence filtering</i>	Yy0, Yd1, Yy2, Yd3, Yy4, Yd5, Yy6, Yd7, Yy8, Yd9, Yy10, Yd11, Ydy0	Yy0, 0°	

Description	Range	Default	Setting
W2 Interposing CT Multiplier <i>Winding 2 scaling factor</i>	0.25,0.26...3.00 x	1.00 x	
W2 Interposing CT Connection <i>Winding 2 transformer vector group compensation and/or zero sequence filtering</i>	Yy0, Yd1, Yy2, Yd3, Yy4, Yd5, Yy6, Yd7, Yy8, Yd9, Yy10, Yd11, Ydy0	Yy0, 0°	
W3 Interposing CT Multiplier <i>Winding 3 scaling factor</i>	0.25,0.26...3.00 x	1.00 x	
W3 Interposing CT Connection <i>Winding 3 transformer vector group compensation and/or zero sequence filtering</i>	Yy0, Yd1, Yy2, Yd3, Yy4, Yd5, Yy6, Yd7, Yy8, Yd9, Yy10, Yd11, Ydy0	Yy0, 0°	
W4 Interposing CT Multiplier <i>Winding 4 scaling factor</i>	0.25,0.26...3.00 x	1.00 x	
W4 Interposing CT Connection <i>Winding 4 transformer vector group compensation and/or zero sequence filtering</i>	Yy0, Yd1, Yy2, Yd3, Yy4, Yd5, Yy6, Yd7, Yy8, Yd9, Yy10, Yd11, Ydy0	Yy0, 0°	
W5 Interposing CT Multiplier <i>Winding 5 scaling factor</i>	0.25,0.26...3.00 x	1.00 x	
W5 Interposing CT Connection <i>Winding 5 transformer vector group compensation and/or zero sequence filtering</i>	Yy0, Yd1, Yy2, Yd3, Yy4, Yd5, Yy6, Yd7, Yy8, Yd9, Yy10, Yd11, Ydy0	Yy0, 0°	
87 Inrush Inhibit <i>Selects whether the biased differential characteristic is inhibited from operating when magnetising inrush is detected</i>	Disabled, Enabled	Enabled	
87 Inrush Bias <i>Selects the bias method used for magnetising inrush</i> <i>Phase – Segregated, each phase blocks itself.</i> <i>Cross – Blocked, each phase can block the operation of other phases (Modular 1 method).</i> <i>Sum - Of Squares, each phase blocks itself using the square root of the sum of squares of the even harmonics.(Improves Switch On To Fault performance when REF not applied).</i>	Phase, Cross, Sum	Cross	
87 Inrush Setting <i>The magnetising inrush detector operates when the even harmonics in the differential operate current exceed a set percentage of the differential operate current</i>	0.1,0.11...0.50 xld	0.20 xld	
87 Bias Differential <i>Selects whether the transformer differential protection element is enabled</i>	Disabled, Enabled	Enabled	
87 Initial Setting <i>The initial unbiased pickup level</i>	0.1,0.15...2.00 xln	0.2 xln	
87 Bias Slope <i>The bias slope varies the pickup level to compensates for CT measuring errors and tap changer not mid tap errors as the through current (bias) increases</i>	0,0.05...0.7 x	0.2 x	
87 Bias Slope Limit <i>At this point in the characteristics the bias slope increases tot provide increased security when additional measuring errors are introduced due to CT saturation effects.</i>	1,2...20 xln	4 xln	
87 Delay <i>The operation of the differential may be</i>	0,0.005...1 s	0.005 s	

Description	Range	Default	Setting
<i>delayed to cater for special system conditions e.g. for use on cable circuits a delay of 5ms is recommended</i>			
87HS Differential Highset <i>Selects whether the differential Highset element is enabled. Note this element is never blocked by magnetising inrush</i>	Disabled, Enabled	Disabled	
87HS Setting <i>The differential setting pickup setting</i>	1,2...30 xIn	4 xIn	
87HS Delay <i>The operation of the differential may be delayed to cater for special system conditions e.g. for use on cable circuits a delay of 5ms is recommended</i>	0,0.005...1 s	0.005 s	

2.4 Restricted E/F 1 Menu

Description	Range	Default	Setting
Gn 87REF-1 Element <i>High impedance restricted earth fault current element 1</i>	Disabled, Enabled	Disabled	
Gn 87REF-1 Setting ¹ <i>Pickup level</i>	0.020,0.025...0.960 xIn	0.200 xIn	
Gn 87REF-1 Delay <i>Pickup delay</i>	0,0.0025...864000 s	0.0000	

1) REF versions have minimum setting of 0.020, SREF versions have minimum setting of 0.005xIn.

2.5 Restricted E/F 2 Menu

Description	Range	Default	Setting
Gn 87REF-2 Element <i>High impedance restricted earth fault current element 2</i>	Disabled, Enabled	Disabled	
Gn 87REF-2 Setting ¹ <i>Pickup level</i>	0.020,0.025...0.960 xIn	0.200 xIn	
Gn 87REF-2 Delay <i>Pickup delay</i>	0,0.0025...864000 s	0.0000	

1) REF versions have minimum setting of 0.020, SREF versions have minimum setting of 0.005xIn.

2.6 Restricted E/F 3 Menu

Description	Range	Default	Setting
Gn 87REF-3 Element <i>High impedance restricted earth fault current element 3</i>	Disabled, Enabled	Disabled	
Gn 87REF-3 Setting ¹ <i>Pickup level</i>	0.020,0.025...0.960 xIn	0.200 xIn	
Gn 87REF-3 Delay <i>Pickup delay</i>	0,0.0025...864000 s	0.0000	

1) REF versions have minimum setting of 0.020, SREF versions have minimum setting of 0.005xIn.

2.7 Standby E/F Menu

Description	Range	Default	Setting
Gn 51G-1 Element <i>Enables or disables IDMTL Earth fault element</i>	Disabled, Enabled	Disabled	
Gn 51G-1 Setting <i>IDMTL Pickup level</i>	0.05,0.10...2.5 xIn	0.5 xIn	
Gn 51G-1 Char <i>Selects IDMTL characteristic curve or DTL operation</i>	IEC-NI, IEC-VI, IEC-EI, IEC-LTI, ANSI-MI, ANSI-VI, ANSI-EI, DTL	IEC-NI	
Gn 51G-1 Time Mult (IEC/ANSI) <i>Time multiplier (applicable to IEC and ANSI curves but not DTL selection)</i>	0.025, 0.050...1.600	1.000	

Description	Range	Default	Setting
Gn 51G-1 Delay (DTL) <i>Delay (applicable only when DTL is selected for characteristic)</i>	0, 0.01...20 s	5 s	
Gn 51G-1 Reset <i>Selects between an ANSI decaying reset characteristic or a definite time reset</i>	(ANSI) Decaying, INST, 1,2...60 s	INST	
Gn 51G-2 Element <i>Enables or disables IDMTL Earth fault element</i>	Disabled, Enabled	Disabled	
Gn 51G-2 Setting <i>IDMTL Pickup level</i>	0.05,0.10...2.5 xIn	0.6 xIn	
Gn 51G-2 Char <i>Selects IDMTL characteristic curve or DTL operation</i>	IEC-NI, IEC-VI, IEC-EI, IEC-LTI, ANSI-MI, ANSI-VI, ANSI-EI, DTL	IEC-NI	
Gn 51G-2 Time Mult (IEC/ANSI) <i>Time multiplier (applicable to IEC and ANSI curves but not DTL selection)</i>	0.025, 0.050...1.600	1.000	
Gn 51G-2 Delay (DTL) <i>Delay (applicable only when DTL is selected for characteristic)</i>	0, 0.01...20 s	5 s	
Gn 51G-2 Reset <i>Selects between an ANSI decaying reset characteristic or a definite time reset</i>	(ANSI) Decaying, INST, 1,2...60 s	INST	
Gn 50G Element <i>Enables or disables INST/DTL Earth fault element</i>	Disabled, Enabled	Disabled	
Gn 50G Setting <i>INST/DTL Pickup level</i>	0.05, 0.10...25 xIn	2 xIn	
Gn 50G Delay <i>INST/DTL Pickup delay</i>	0,0.01...864000 s	0.01	

2.8 Voltage Menu

Description	Range	Default	Setting
Gn U/V Guard Element <i>Selects whether the under voltage guard element which can be applied to both the voltage and frequency elements is enabled</i>	Disabled, Enabled	Enabled	
Gn U/V Guard Setting <i>When the voltage drops below this level the element operates to provide a guard to prevent other elements operating due to the Circuit breaker opening</i>	0.01,0.02...2.5 xVn	0.1 xVn	
Gn U/V Guard Delay <i>Pickup delay</i>	0,0.01...864000 s	0 s	
Gn 27/59-1 Element <i>Selects whether the Under/Over voltage element stage 1 is enabled</i>	Disabled, Enabled	Disabled	
Gn 27/59-1 Operation <i>Selects between Undervoltage and Overvoltage pickup for this element</i>	Under, Over	Over	
Gn 27/59-1 Setting <i>Under or over voltage pickup level</i>	0.01,0.02...2.5 xVn	1.15 xVn	
Gn 27/59-1 Hysteresis <i>Sets the pickup to dropoff thresholds e.g. 3% on Overlevel picks up above pickup setting and drops off below 97% of setting, 3% on Underlevel picks up below setting and drops off above 103% of setting</i>	0,0.1...80 %	0.1 %	
Gn 27/59-1 Delay <i>Pickup delay</i>	0,0.01...864000 s	0.1 s	
Gn 27/59-1 U/V Guarded <i>Selects whether U/V Guard element can block the operation of this element</i>	No, Yes	Yes	
Gn 27/59-2 Element	Disabled, Enabled	Disabled	

Description	Range	Default	Setting
<i>Selects whether the Under/Over voltage element stage 2 is enabled</i>			
Gn 27/59-2 Operation <i>Selects between Undervoltage and Overvoltage pickup for this element</i>	Under, Over	Over	
Gn 27/59-2 Setting <i>Under or over voltage pickup level</i>	0.01,0.02...2.5 xVn	1.10 xVn	
Gn 27/59-2 Hysteresis <i>Sets the pickup to dropoff thresholds e.g. 3% on Overlevel picks up above pickup setting and drops off below 97% of setting, 3% on Underlevel picks up below setting and drops off above 103% of setting</i>	0,0.1...80 %	0.1 %	
Gn 27/59-2 Delay <i>Pickup delay</i>	0.1,0.2...864000 s	0.2 s	
Gn 27/59-2 U/V Guarded <i>Selects whether U/V Guard element can block the operation of this element</i>	No, Yes	Yes	
Gn 27/59-3 Element <i>Selects whether the Under/Over voltage element stage 1 is enabled</i>	Disabled, Enabled	Disabled	
Gn 27/59-3 Operation <i>Selects between Undervoltage and Overvoltage pickup for this element</i>	Under, Over	Under	
Gn 27/59-3 Setting <i>Under or over voltage pickup level</i>	0.01,0.02...2.5 xVn	0.80 xVn	
Gn 27/59-3 Hysteresis <i>Sets the pickup to dropoff thresholds e.g. 3% on Overlevel picks up above pickup setting and drops off below 97% of setting, 3% on Underlevel picks up below setting and drops off above 103% of setting</i>	0,0.1...80 %	0.1 %	
Gn 27/59-3 Delay <i>Pickup delay</i>	0.1,0.2...864000 s	1 s	
Gn 27/59-3 U/V Guarded <i>Selects whether U/V Guard element can block the operation of this element</i>	No, Yes	Yes	
Gn 27/59-4 Element <i>Selects whether the Under/Over voltage element stage 1 is enabled</i>	Disabled, Enabled	Disabled	
Gn 27/59-4 Operation <i>Selects between Undervoltage and Overvoltage pickup for this element</i>	Under, Over	Over	
Gn 27/59-4 Setting <i>Under or over voltage pickup level</i>	0.01,0.02...2.5 xVn	0.70 xVn	
Gn 27/59-4 Hysteresis <i>Sets the pickup to dropoff thresholds e.g. 3% on Overlevel picks up above pickup setting and drops off below 97% of setting, 3% on Underlevel picks up below setting and drops off above 103% of setting</i>	0,0.1...80 %	0.1 %	
Gn 27/59-4 Delay <i>Pickup delay</i>	0,0.01...864000 s	1 s	
Gn 27/59-4 U/V Guarded <i>Selects whether U/V Guard element can block the operation of this element</i>	No, Yes	Yes	

2.9 Frequency Menu

Description	Range	Default	Setting
Gn 81-1 Element <i>Selects whether the Under/Over frequency element stage 1 is enabled</i>	Disabled, Enabled	Disabled	
Gn 81-1 Operation <i>Selects between Underfrequency and</i>	Under, Over	Under	

Description	Range	Default	Setting
<i>Overfrequency pickup for this element</i>			
Gn 81-1 Setting <i>Under or over frequency pickup level</i>	40.00,40.01...70.00 Hz	49.50 Hz	
Gn 81-1 Hysteresis <i>Sets the pickup to dropoff thresholds e.g. 3% on Overlevel picks up above pickup setting and drops off below 97% of setting, 3% on Underlevel picks up below setting and drops off above 103% of setting</i>	0,0.1...80 %	0.1 %	
Gn 81-1 Delay <i>Pickup delay</i>	0.1,0.2...864000 s	1 s	
Gn 81-1 U/V Guarded <i>Selects whether U/V Guard element can block the operation of this element</i>	No, Yes	Yes	
Gn 81-2 Element <i>Selects whether the Under/Over frequency element stage 2 is enabled</i>	Disabled, Enabled	Disabled	
Gn 81-2 Operation <i>Selects between Underfrequency and Overfrequency pickup for this element</i>	Under, Over	Under	
Gn 81-2 Setting <i>Under or over frequency pickup level</i>	40.00,40.01...70.00 Hz	49.00 Hz	
Gn 81-2 Hysteresis <i>Sets the pickup to dropoff thresholds e.g. 3% on Overlevel picks up above pickup setting and drops off below 97% of setting, 3% on Underlevel picks up below setting and drops off above 103% of setting</i>	0,0.1...80 %	0.1 %	
Gn 81-2 Delay <i>Pickup delay</i>	0.1,0.2...864000 s	0.8 s	
Gn 81-2 U/V Guarded <i>Selects whether U/V Guard element can block the operation of this element</i>	No, Yes	Yes	
Gn 81-3 Element <i>Selects whether the Under/Over frequency element stage 3 is enabled</i>	Disabled, Enabled	Disabled	
Gn 81-3 Operation <i>Selects between Underfrequency and Overfrequency pickup for this element</i>	Under, Over	Under	
Gn 81-3 Setting <i>Under or over frequency pickup level</i>	40.00,40.01...70.00 Hz	48.00 Hz	
Gn 81-3 Hysteresis <i>Sets the pickup to dropoff thresholds e.g. 3% on Overlevel picks up above pickup setting and drops off below 97% of setting, 3% on Underlevel picks up below setting and drops off above 103% of setting</i>	0,0.1...80 %	0.1 %	
Gn 81-3 Delay <i>Pickup delay</i>	0.1,0.2...864000 s	0.6 s	
Gn 81-3 U/V Guarded <i>Selects whether U/V Guard element can block the operation of this element</i>	No, Yes	Yes	
Gn 81-4 Element <i>Selects whether the Under/Over frequency element stage 1 is enabled</i>	Disabled, Enabled	Disabled	
Gn 81-4 Operation <i>Selects between Underfrequency and Overfrequency pickup for this element</i>	Under, Over	Under	
Gn 81-4 Setting <i>Under or over frequency pickup level</i>	40.00,40.01...70.00 Hz	47.50 Hz	
Gn 81-1 Hysteresis <i>Sets the pickup to dropoff thresholds e.g.</i>	0,0.1...80 %	0.1 %	

Description	Range	Default	Setting
3% on Overlevel picks up above pickup setting and drops off below 97% of setting, 3% on Underlevel picks up below setting and drops off above 103% of setting			
Gn 81-4 Delay Pickup delay	0.1,0.2...864000 s	0.4 s	
Gn 81-4 U/V Guarded Selects whether U/V Guard element can block the operation of this element	No, Yes	Yes	

2.10 Overfluxing Menu

Description	Range	Default	Setting
Gn Voltage Multiplier Voltage scaling factor to compensate for any voltage measuring errors	0.500,0.501...1.5 x	1 x	
Gn 24DT-1 Element Selects whether the definite time Overfluxing element stage 1 is enabled	Disabled, Enabled	Disabled	
Gn 24DT-1 Setting Pickup level	0.1,0.11...2.00	1.10 x	
Gn 24DT-1 Hysteresis Sets the pickup to dropoff thresholds e.g. 3% on Overlevel picks up above pickup setting and drops off below 97% of setting, 3% on Underlevel picks up below setting and drops off above 103% of setting	0,0.1...80 %	0.1 %	
Gn 24DT-1 Delay Pickup delay	0.1,0.2...864000 s	6 s	
Gn 24DT-2 Element Selects whether the definite time Overfluxing element stage 2 is enabled	Disabled, Enabled	Disabled	
Gn 24DT-2 Setting Pickup level	0.1,0.11...2.00	1.15 x	
Gn 24DT-2 Hysteresis Sets the pickup to dropoff thresholds e.g. 3% on Overlevel picks up above pickup setting and drops off below 97% of setting, 3% on Underlevel picks up below setting and drops off above 103% of setting	0,0.1...80 %	0.1 %	
Gn 24DT-2 Delay Pickup delay	0.1,0.2...864000 s	6 s	
Gn 24IT Char Selects whether the inverse time Overfluxing element is enabled	Disabled, Enabled	Disabled	
Gn 24IT Reset Selects between an INSTantaneous reset characteristic or a definite time reset	INST, 1,2, ...1000 s	INST	
Gn 24IT X0 Pickup Setting Initial user defined pickup level	1.00,1.01...2.00	1.10 x	
Gn 24IT Y0 Point Setting Initial user defined pickup delay	0.1,0.2...20000 s	20000 s	
Gn 24IT X1 Point Setting Next user defined pickup level	1.00,1.01...2.00	1.14 x	
Gn 24IT Y1 Point Setting Next user defined pickup delay	0.1,0.2...20000 s	1200 s	
Gn 24IT X2 Point Setting Next user defined pickup level	1.00,1.01...2.00	1.16 x	
Gn 24IT Y2 Point Setting Next user defined pickup delay	0.1,0.2...20000 s	540 s	
Gn 24IT X3 Point Setting	1.00,1.01...2.00	1.21 x	

Description	Range	Default	Setting
<i>Next user defined pickup level</i>			
Gn 24IT Y3 Point Setting <i>Next user defined pickup delay</i>	0.1,0.2...20000 s	240 s	
Gn 24IT X4 Point Setting <i>Next user defined pickup level</i>	1.00,1.01...2.00	1.24 x	
Gn 24IT Y4 Point Setting <i>Next user defined pickup delay</i>	0.1,0.2...20000 s	120 s	
Gn 24IT X5 Point Setting <i>Next user defined pickup level</i>	1.00,1.01...2.00	1.28 x	
Gn 24IT Y5 Point Setting <i>Next user defined pickup delay</i>	0.1,0.2...20000 s	60 s	
Gn 24IT X6 Point Setting <i>Next user defined pickup level</i>	1.00,1.01...2.00	1.40 x	
Gn 24IT Y6 Point Setting <i>Next user defined pickup delay</i>	0.1,0.2...20000 s	20 s	

2.11 Status Input Menu

Description	Range	Default	Setting
Aux I/P 1 Pickup Delay <i>Delay on pickup of DC Status input 1</i>	0.000,0.005...864000 s	0 s	
Aux I/P 2 Pickup Delay	0.000,0.005...864000 s	0 s	
Aux I/P 3 Pickup Delay	0.000,0.005...864000 s	0 s	
Aux I/P 4 Pickup Delay ¹	0.000,0.005...864000 s	0 s	
Aux I/P 5 Pickup Delay ¹	0.000,0.005...864000 s	0 s	
Aux I/P 6 Pickup Delay ¹	0.000,0.005...864000 s	0 s	
Aux I/P 7 Pickup Delay ¹	0.000,0.005...864000 s	0 s	
Aux I/P 8 Pickup Delay ¹	0.000,0.005...864000 s	0 s	
Aux I/P 9 Pickup Delay ¹	0.000,0.005...864000 s	0 s	
Aux I/P 10 Pickup Delay ¹	0.000,0.005...864000 s	0 s	
Aux I/P 11 Pickup Delay ¹	0.000,0.005...864000 s	0 s	
Aux I/P 12 Pickup Delay ¹	0.000,0.005...864000 s	0 s	
Aux I/P 13 Pickup Delay ¹	0.000,0.005...864000 s	0 s	
Aux I/P 14 Pickup Delay ¹	0.000,0.005...864000 s	0 s	
Aux I/P 15 Pickup Delay ¹	0.000,0.005...864000 s	0 s	
Aux I/P 16 Pickup Delay ¹	0.000,0.005...864000 s	0 s	
Aux I/P 17 Pickup Delay ¹	0.000,0.005...864000 s	0 s	
Aux I/P 18 Pickup Delay ¹	0.000,0.005...864000 s	0 s	
Aux I/P 19 Pickup Delay ¹	0.000,0.005...864000 s	0 s	
Inhibit 87 <i>Selects which inputs inhibit the 87 element</i>	NONE, 1...19 ²	NONE	
Inhibit 87HS <i>Selects which inputs inhibit the 87HS element</i>	NONE, 1...19 ²	NONE	
Inhibit 87REF-1 <i>Selects which inputs inhibit the 87REF-1 element</i>	NONE, 1...19 ²	NONE	
Inhibit 87REF-2 <i>Selects which inputs inhibit the 87REF-2 element</i>	NONE, 1...19 ²	NONE	
Inhibit 87REF-3 <i>Selects which inputs inhibit the 87REF-3 element</i>	NONE, 1...19 ²	NONE	
Inhibit 51G-1 <i>Selects which inputs inhibit the 51G-1 element</i>	NONE, 1...19 ²	NONE	
Inhibit 51G-2 <i>Selects which inputs inhibit the 51G-2 element</i>	NONE, 1...19 ²	NONE	
Inhibit 50G <i>Selects which inputs inhibit the 50G element</i>	NONE, 1...19 ²	NONE	
Inhibit 27/59-1	NONE, 1...19 ²	NONE	

Description	Range	Default	Setting
<i>Selects which inputs inhibit the 27/59-1 element</i>			
Inhibit 27/59-2 <i>Selects which inputs inhibit the 27/59-1 element</i>	NONE, 1...19 ²	NONE	
Inhibit 27/59-3 <i>Selects which inputs inhibit the 27/59-1 element</i>	NONE, 1...19 ²	NONE	
Inhibit 27/59-4 <i>Selects which inputs inhibit the 27/59-1 element</i>	NONE, 1...19 ²	NONE	
Inhibit 81-1 <i>Selects which inputs inhibit the 81-1 element</i>	NONE, 1...19 ²	NONE	
Inhibit 81-2 <i>Selects which inputs inhibit the 81-2 element</i>	NONE, 1...19 ²	NONE	
Inhibit 81-3 <i>Selects which inputs inhibit the 81-3 element</i>	NONE, 1...19 ²	NONE	
Inhibit 81-4 <i>Selects which inputs inhibit the 81-4 element</i>	NONE, 1...19 ²	NONE	
Inhibit 24DT-1 <i>Selects which inputs inhibit the 24DT-1 element</i>	NONE, 1...19 ²	NONE	
Inhibit 24DT-2 <i>Selects which inputs inhibit the 24DT-2 element</i>	NONE, 1...19 ²	NONE	
Inhibit 24IT <i>Selects which inputs inhibit the 24IT element</i>	NONE, 1...19 ²	NONE	
Trip Circuit Fail <i>Selects which inputs are monitoring trip circuits, inputs should normally also be selected as Inverted Inputs (see below)</i>	NONE, 1...19 ²	NONE	
Trigger Wave Rec <i>Selects which inputs can trigger a waveform record</i>	NONE, 1...19 ²	NONE	
Trigger Data Rec <i>Selects which inputs can trigger a data record</i>	NONE, 1...19 ²	NONE	
Select Group 1 <i>Switches active setting group to group 1</i>	NONE, 1...19 ²	NONE	
Select Group 2 <i>Switches active setting group to group 2</i>	NONE, 1...19 ²	NONE	
Select Group 3 <i>Switches active setting group to group 3</i>	NONE, 1...19 ²	NONE	
Select Group 4 <i>Switches active setting group to group 4</i>	NONE, 1...19 ²	NONE	
Select Group 5 <i>Switches active setting group to group 5</i>	NONE, 1...19 ²	NONE	
Select Group 6 <i>Switches active setting group to group 6</i>	NONE, 1...19 ²	NONE	
Select Group 7 <i>Switches active setting group to group 7</i>	NONE, 1...19 ²	NONE	
Select Group 8 <i>Switches active setting group to group 8</i>	NONE, 1...19 ²	NONE	
Clock Sync. <i>Selects which input is used to synchronise the real time clock</i>	NONE, 1...19 ²	NONE	
Inverted Inputs <i>Selects which inputs pickup when voltage is removed, often used when monitoring trip circuits.</i>	NONE, 1...19 ²	NONE	

1) Only when fitted.

2) 19 status inputs represents maximum configuration for 5W relay.

2.12 Reylogic Control Menu

Description	Range	Default	Setting
General Logic <i>Selects whether the logic diagram is enabled, if disabled then no outputs will be driven.</i>	Enable, Disable	Enable	

2.13 Reylogic Element Menu

Description	Range	Default	Setting
Inhibit 87 Drop Off Delay <i>Delay before inhibit is removed from 87 element after Inhibit 87 is de-energised.</i>	0,1...60000 ms	10 ms	
Inhibit 87HS Drop Off Delay <i>Delay before inhibit is removed from 87HS element after Inhibit 87HS is de-energised.</i>	0,1...60000 ms	10 ms	
Trip Cct Fail Pickup Delay <i>Delay before trip circuit failure picks up. Used in conjunction with STATUS INPUT MENU/Trip Circuit Fail setting to configure how many trip circuits are being monitored.</i>	0,1...60000 ms	400 ms	

2.14 Output Relay Menu

Description	Range	Default	Setting
87 <i>Biased Differential operated</i>	NONE, 1...21 ¹	4,5	
87HS <i>Differential Highset operated</i>	NONE, 1...21 ¹	4,5	
87REF-1 <i>High Impedance Restricted Earth Fault 1 operated</i>	NONE, 1...21 ¹	4,5	
87REF-2 <i>High Impedance Restricted Earth Fault 2 operated</i>	NONE, 1...21 ¹	4,5	
87REF-3 <i>High Impedance Restricted Earth Fault 3 operated</i>	NONE, 1...21 ¹	4,5	
51G-1 <i>IDMTL Standby Earth Fault Stage 1 operated</i>	NONE, 1...21 ¹	4,5	
51G-2 <i>IDMTL Standby Earth Fault Stage 2 operated</i>	NONE, 1...21 ¹	4,5	
50G <i>DTL Standby Earth Fault operated</i>	NONE, 1...21 ¹	4,5	
27/59-1 <i>Under/Overtension stage 1 operated</i>	NONE, 1...21 ¹	NONE	
27/59-2 <i>Under/Overtension stage 2 operated</i>	NONE, 1...21 ¹	NONE	
27/59-3 <i>Under/Overtension stage 3 operated</i>	NONE, 1...21 ¹	NONE	
27/59-4 <i>Under/Overtension stage 4 operated</i>	NONE, 1...21 ¹	NONE	
81-1 <i>Under/Over frequency stage 1 operated</i>	NONE, 1...21 ¹	NONE	
81-2 <i>Under/Over frequency stage 2 operated</i>	NONE, 1...21 ¹	NONE	
81-3 <i>Under/Over frequency stage 3 operated</i>	NONE, 1...21 ¹	NONE	

Description	Range	Default	Setting
81-4 <i>Under/Over frequency stage 4 operated</i>	NONE, 1...21 ¹	NONE	
24DT-1 <i>DTL Overfluxing element stage 1 operated</i>	NONE, 1...21 ¹	4,5	
24DT-2 <i>DTL Overfluxing element stage 2 operated</i>	NONE, 1...21 ¹	4,5	
24IT <i>Inverse Time Overfluxing element operated</i>	NONE, 1...21 ¹	4,5	
Phase A <i>A phase A element operated</i>	NONE, 1...21 ¹	NONE	
Phase B <i>A phase B element operated</i>	NONE, 1...21 ¹	NONE	
Phase C <i>A phase C element operated</i>	NONE, 1...21 ¹	NONE	
Phase N <i>A phase N element operated</i>	NONE, 1...21 ¹	NONE	
General Starter <i>A starter element is picked up. Useful when testing individual functions</i>	NONE, 1...21 ¹	NONE	
General Trip <i>An element has operated. Useful when testing individual functions</i>	NONE, 1...21 ¹	NONE	
Trip Circuit Fail <i>A trip circuit has failed, look at status input Leds to find out which one</i>	NONE, 1...21 ¹	NONE	
New Wave Stored <i>The waveform recorder has stored new information Note: this is a pulsed output</i>	NONE, 1...21 ¹	NONE	
New Data Stored <i>The data recorder has stored new information Note: this is a pulsed output</i>	NONE, 1...21 ¹	NONE	
Aux I/P 1 Operated <i>DC Status 1 has operated</i>	NONE, 1...21 ¹	NONE	
Aux I/P 2 Operated	NONE, 1...21 ¹	NONE	
Aux I/P 3 Operated	NONE, 1...21 ¹	NONE	
Aux I/P 4 Operated ²	NONE, 1...21 ¹	NONE	
Aux I/P 5 Operated ²	NONE, 1...21 ¹	NONE	
Aux I/P 6 Operated ²	NONE, 1...21 ¹	NONE	
Aux I/P 7 Operated ²	NONE, 1...21 ¹	NONE	
Aux I/P 8 Operated ²	NONE, 1...21 ¹	NONE	
Aux I/P 9 Operated ²	NONE, 1...21 ¹	NONE	
Aux I/P 10 Operated ²	NONE, 1...21 ¹	NONE	
Aux I/P 11 Operated ²	NONE, 1...21 ¹	NONE	
Aux I/P 12 Operated ²	NONE, 1...21 ¹	NONE	
Aux I/P 13 Operated ²	NONE, 1...21 ¹	NONE	
Aux I/P 14 Operated ²	NONE, 1...21 ¹	NONE	
Aux I/P 15 Operated ²	NONE, 1...21 ¹	NONE	
Aux I/P 16 Operated ²	NONE, 1...21 ¹	NONE	
Aux I/P 17 Operated ²	NONE, 1...21 ¹	NONE	
Aux I/P 18 Operated ²	NONE, 1...21 ¹	NONE	
Aux I/P 19 Operated ²	NONE, 1...21 ¹	NONE	
Hand Reset Outputs <i>Relays selected, as Hand Reset will remain latched until manually reset from front panel or via communications link or by removing DC Supply. By default relays are Self Resetting and will reset when the driving signal is removed.</i>	NONE, 1...21 ¹	NONE	
Protection Healthy <i>Relays selected are energised whilst relay self-monitoring does NOT detect</i>	NONE, 1...21 ¹	1	

Description	Range	Default	Setting
<i>any hardware or software errors and DC Supply is healthy. A changeover contact or normally closed contact may be used to generate Protection Defective from this output</i>			

1) 21 output relays represents maximum configuration.

2) Only when fitted.

2.15 OP Relay Timing Menu

Description	Range	Default	Setting
Min Operate Time 1 <i>Minimum operate time of output relay 1</i>	0.02, 0.04...60 s	0.1 s	
Min Operate Time 2 <i>Minimum operate time of output relay 2</i>	0.02, 0.04...60 s	0.1 s	
Min Operate Time 3 <i>Minimum operate time of output relay 3</i>	0.02, 0.04...60 s	0.1 s	
Min Operate Time 4 <i>Minimum operate time of output relay 4</i>	0.02, 0.04...60 s	0.1 s	
Min Operate Time 5 <i>Minimum operate time of output relay 5</i>	0.02, 0.04...60 s	0.1 s	
Min Operate Time 6 ¹ <i>Minimum operate time of output relay 6</i>	0.02, 0.04...60 s	0.1 s	
Min Operate Time 7 ¹ <i>Minimum operate time of output relay 7</i>	0.02, 0.04...60 s	0.1 s	
Min Operate Time 8 ¹ <i>Minimum operate time of output relay 8</i>	0.02, 0.04...60 s	0.1 s	
Min Operate Time 9 ¹ <i>Minimum operate time of output relay 9</i>	0.02, 0.04...60 s	0.1 s	
Min Operate Time 10 ¹ <i>Minimum operate time of output relay 10</i>	0.02, 0.04...60 s	0.1 s	
Min Operate Time 11 ¹ <i>Minimum operate time of output relay 11</i>	0.02, 0.04...60 s	0.1 s	
Min Operate Time 12 ¹ <i>Minimum operate time of output relay 12</i>	0.02, 0.04...60 s	0.1 s	
Min Operate Time 13 ¹ <i>Minimum operate time of output relay 13</i>	0.02, 0.04...60 s	0.1 s	
Min Operate Time 14 ¹ <i>Minimum operate time of output relay 14</i>	0.02, 0.04...60 s	0.1 s	
Min Operate Time 15 ¹ <i>Minimum operate time of output relay 15</i>	0.02, 0.04...60 s	0.1 s	
Min Operate Time 16 ¹ <i>Minimum operate time of output relay 16</i>	0.02, 0.04...60 s	0.1 s	
Min Operate Time 17 ¹ <i>Minimum operate time of output relay 17</i>	0.02, 0.04...60 s	0.1 s	
Min Operate Time 18 ¹ <i>Minimum operate time of output relay 18</i>	0.02, 0.04...60 s	0.1 s	
Min Operate Time 19 ¹ <i>Minimum operate time of output relay 19</i>	0.02, 0.04...60 s	0.1 s	
Min Operate Time 20 ¹ <i>Minimum operate time of output relay 20</i>	0.02, 0.04...60 s	0.1 s	
Min Operate Time 21 ¹ <i>Minimum operate time of output relay 22</i>	0.02, 0.04...60 s	0.1 s	

1) 21 output relays represents maximum configuration.

2.16 LED Menu

Description	Range	Default	Setting
87 <i>Biased Differential operated</i>	NONE, 1...32	17	
87 HS <i>Differential Highset operated</i>	NONE, 1...32	19	
87REF-1 <i>High Impedance Restricted Earth Fault 1</i>	NONE, 1...32	5,19	

Description	Range	Default	Setting
<i>operated</i>			
87REF-2 <i>High Impedance Restricted Earth Fault 2 operated</i>	NONE, 1...32	6,19	
87REF-3 <i>High Impedance Restricted Earth Fault 3 operated</i>	NONE, 1...32	7,19	
51G-1 <i>IDMTL Standby Earth Fault Stage 1 operated</i>	NONE, 1...32	20	
51G-2 <i>IDMTL Standby Earth Fault Stage 2 operated</i>	NONE, 1...32	20	
50G <i>DTL Standby Earth Fault operated</i>	NONE, 1...32	20	
27/59-1 <i>Under/Oversvoltage stage 1 operated</i>	NONE, 1...32	21	
27/59-2 <i>Under/Oversvoltage stage 2 operated</i>	NONE, 1...32	21	
27/59-3 <i>Under/Oversvoltage stage 3 operated</i>	NONE, 1...32	21	
27/59-4 <i>Under/Oversvoltage stage 4 operated</i>	NONE, 1...32	21	
81-1 <i>Under/Over frequency stage 1 operated</i>	NONE, 1...32	22	
81-2 <i>Under/Over frequency stage 2 operated</i>	NONE, 1...32	22	
81-3 <i>Under/Over frequency stage 3 operated</i>	NONE, 1...32	22	
81-4 <i>Under/Over frequency stage 4 operated</i>	NONE, 1...32	22	
24DT-1 <i>DTL Overfluxing element stage 1 operated</i>	NONE, 1...32	23	
24DT-2 <i>DTL Overfluxing element stage 2 operated</i>	NONE, 1...32	23	
24IT <i>Inverse Time Overfluxing element operated</i>	NONE, 1...32	23	
Phase A <i>A phase A element operated</i>	NONE, 1...32	2	
Phase B <i>A phase B element operated</i>	NONE, 1...32	3	
Phase C <i>A phase C element operated</i>	NONE, 1...32	4	
Phase N <i>A phase N element operated</i>	NONE, 1...32	NONE	
General Starter <i>A starter element is picked up. Useful when testing individual functions</i>	NONE, 1...32	NONE	
General Trip <i>An element has operated. Useful when testing individual functions</i>	NONE, 1...32	NONE	
Trip Circuit Fail <i>A trip circuit has failed, look at status inputs Leds to find out which one</i>	NONE, 1...32	24	
New Data Stored <i>The waveform recorder has stored new information</i>	NONE, 1...32	NONE	
Aux I/P 1 Operated <i>DC Status 1 has operated</i>	NONE, 1...32	9	
Aux I/P 2 Operated	NONE, 1...32	10	
Aux I/P 3 Operated	NONE, 1...32	11	

Description	Range	Default	Setting
Aux I/P 4 Operated ¹	NONE, 1...32	12	
Aux I/P 5 Operated ¹	NONE, 1...32	13	
Aux I/P 6 Operated ¹	NONE, 1...32	14	
Aux I/P 7 Operated ¹	NONE, 1...32	15	
Aux I/P 8 Operated ¹	NONE, 1...32	16	
Aux I/P 9 Operated ¹	NONE, 1...32	25	
Aux I/P 10 Operated ¹	NONE, 1...32	26	
Aux I/P 11 Operated ¹	NONE, 1...32	27	
Aux I/P 12 Operated ¹	NONE, 1...32	NONE	
Aux I/P 13 Operated ¹	NONE, 1...32	NONE	
Aux I/P 14 Operated ¹	NONE, 1...32	NONE	
Aux I/P 15 Operated ¹	NONE, 1...32	NONE	
Aux I/P 16 Operated ¹	NONE, 1...32	NONE	
Aux I/P 17 Operated ¹	NONE, 1...32	NONE	
Aux I/P 18 Operated ¹	NONE, 1...32	NONE	
Aux I/P 19 Operated ¹	NONE, 1...32	NONE	
Self Reset LEDs <i>Leds selected, as Self Reset will automatically reset when the driving signal is removed. By default all Leds are Hand Reset and must be manually reset either locally via the front fascia or remotely via communications.</i>	NONE, 1...32	NONE	

1) Only when fitted.

2.17 Data Storage Menu

Description	Range	Default	Setting
Clear Faults <i>Clears the Fault Records, useful after routine testing.</i>	NO, YES	NO	
Clear Events <i>Clears the Event Records, useful after routine testing.</i>	NO, YES	NO	
Pre-Trigger Storage <i>Specifies the amount of pre fault data for the waveform records.</i>	10...90 %	20 %	
Data Record Duration ¹ <i>Specifies the duration of the waveform records and the number of records available.</i>	3 Recs x 1 Seconds, 1 Recs x 1 Seconds	3 Recs x 1 Second	
Trigger Waveform <i>Triggers a waveform record.</i>	NO, YES	NO	
Clear Waveforms <i>Clears the Waveform Records, useful after routine testing.</i>	NO, YES	NO	

1) Number of records and duration available is dependent upon relay model

2.18 Communications Menu

Description	Range	Default	Setting
Station Address <i>IEC 60870-5-103 Station Address</i>	0...254	0	
COM1 Protocol <i>Selects protocol to use for COM 1</i>	OFF, IEC60870-5-103, MODBUS-RTU	IEC60870-5-103	
COM1 Baud Rate <i>Sets the communications baud rate for com port 1 (Rear upper Fibre optic port)</i>	75, 110, 300, 600, 1200, 2400, 4800, 9600, 19200, 38400, 57600, 115200	19200	
COM1 Parity <i>Selects whether parity information is used</i>	Even, Odd, None	Even	
COM1 Line Idle <i>Selects the communications line idle sense</i>	Light Off, Light On	Light Off	

Description	Range	Default	Setting
COM1 Data Echo <i>Enables echoing of data from RX port to TX port when operating relays in a Fibre Optic ring configuration</i>	Off, On	Off	
COM2 Protocol <i>Selects protocol to use for COM 2</i>	OFF, IEC60870-5-103, MODBUS-RTU, ASCII	ASCII	
COM2 Baud Rate <i>Sets the communications baud rate for com port 2 (Rear lower Fibre optic port AND Front Fascia RS232 port)</i>	75, 110, 300, 600, 1200, 2400, 4800, 9600, 19200, 38400, 57600, 115200	57600	
COM2 Parity <i>Selects whether parity information is used</i>	Even, Odd, None	Even	
COM2 Line Idle <i>Selects the communications line idle sense</i>	Light Off, Light On	Light Off	
COM2 Data Echo <i>Enables echoing of data from RX port to TX port when operating relays in a Fibre Optic ring configuration</i>	Off, On	Off	
COM2 Direction <i>Selects how Com2 is shared between the front fascia port and the rear fibre optic port. This allows interlocking to prevent remote access whilst an engineer is attached locally on site if IEC870 is on Com2 and Auto-detect is enabled</i>	AUTO-DETECT, FRONT PORT, REAR PORT	AUTO-DETECT	

3 Instruments

INSTRUMENT	DESCRIPTION
[WINDING 1 METERS] --> press down <--	Start of meters for winding 1
W1 Primary Currents 0.00 0.00 0.00 kA	Winding 1 primary currents
W1 Sec'y Currents 0.00 0.00 0.00 A	Winding 1 secondary currents
W1 Nom Currents 0.00 0.00 0.00 xIn	Winding 1 nominal currents
[WINDING 2 METERS] --> press down <--	Start of meters for winding 2
W2 Primary Currents 0.00 0.00 0.00 kA	Winding 2 primary currents
W2 Sec'y Currents 0.00 0.00 0.00 A	Winding 2 secondary currents
W2 Nom Currents 0.00 0.00 0.00 xIn	Winding 2 nominal currents
[WINDING 3 METERS] --> press down <--	Start of meters for winding 3
W3 Primary Currents 0.00 0.00 0.00 kA	Winding 3 primary currents
W3 Sec'y Currents 0.00 0.00 0.00 A	Winding 3 secondary currents
W3 Nom Currents 0.00 0.00 0.00 xIn	Winding 3 nominal currents
[WINDING 4 METERS] --> press down <--	Start of meters for winding 4
W4 Primary Currents 0.00 0.00 0.00 kA	Winding 4 primary currents
W4 Sec'y Currents 0.00 0.00 0.00 A	Winding 4 secondary currents
W4 Nom Currents 0.00 0.00 0.00 xIn	Winding 4 nominal currents
[WINDING 5 METERS] --> press down <--	Start of meters for winding
W5 Primary Currents 0.00 0.00 0.00 kA	Winding 5 primary currents
W5 Sec'y Currents 0.00 0.00 0.00 A	Winding 5 secondary currents
W5 Nom Currents 0.00 0.00 0.00 xIn	Winding 5 nominal currents
[REF 1 METERS] --> press down <--	Start of restricted earth fault 1 meters
REF-1 Pri'y Current 0.0 kA	87REF-1 primary restricted earth fault current
REF-1 Sec'y Current 0.00 A	87REF-1 secondary restricted earth fault current
REF-1 Nom Current 0.00 xIn	87REF-1 nominal restricted earth fault current
[REF 2 METERS] --> press down <--	Start of restricted earth fault 2 meters
REF-2 Pri'y Current 0.0 kA	87REF-2 primary restricted earth fault current
REF-2 Sec Current 0.00 A	87REF-2 secondary restricted earth fault current
REF-2 Nom Current 0.00 xIn	87REF-2 nominal restricted earth fault current
[REF 3 METERS] --> press down <--	Start of restricted earth fault 3 meters
REF-3 Pri'y Current 0.0 kA	87REF-3 primary restricted earth fault current
REF-3 Sec Current 0.00 A	87REF-3 secondary restricted earth fault current

INSTRUMENT	DESCRIPTION
REF-3 Nom Current 0.00 xIn	87REF-3 nominal restricted earth fault current
[STANDBY E/F METERS] --> press down <--	Start of standby earth fault 1 meters
E/F Primary Current 0.0 kA	Standby E/F primary current
E/F Sec'y Current 0.00 A	Standby E/F secondary current
E/F Nom Current 0.00 xIn	Standby E/F nominal currents
51G Status 0 0 %	Operation progress meters for (51G-1,51G-2) IDMTL elements
[VOLTAGE METERS] --> press down <--	Start of Voltage meters
Primary Voltage 0.0 kV	Primary voltage
Secondary Voltage 0.00 kV	Secondary voltage
Nominal Voltage 0.00 xVn	Nominal voltage
Frequency 0.000 Hz	Voltage frequency
Nominal Frequency 0.000 xfn	Nominal Voltage frequency
[OVERFLUXING METERS] --> press down <--	Start of V/f meters
V/f Voltage 0.000 xVn	Nominal V/f Voltage
V/f Value 0.000 xVn/fn	Nominal V/f value
V/f IDMTL Status 0.0 %	Operation progress meter for V/f (24IT) IDMTL element
[BIAS DIFF METERS] --> press down <--	Start of (87) Biased Differential meters
W1 Line Currents 0.00 0.00 0.00 xIn	Winding 1 measured currents
W2 Line Currents 0.00 0.00 0.00 xIn	Winding 2 measured currents
W3 Line Currents 0.00 0.00 0.00 xIn	Winding 3 measured currents
W4 Line Currents 0.00 0.00 0.00 xIn	Winding 4 measured currents
W5 Line Currents 0.00 0.00 0.00 xIn	Winding 5 measured currents
W1 Relay Currents 0.00 0.00 0.00 xIn	Winding 1 currents after Interposing CT correction factors applied
W2 Relay Currents 0.00 0.00 0.00 xIn	Winding 2 currents after Interposing CT correction factors applied
W3 Relay Currents 0.00 0.00 0.00 xIn	Winding 3 currents after Interposing CT correction factors applied
W4 Relay Currents 0.00 0.00 0.00 xIn	Winding 3 currents after Interposing CT correction factors applied
W5 Relay Currents 0.00 0.00 0.00 xIn	Winding 3 currents after Interposing CT correction factors applied
Operate Currents 0.00 0.00 0.00 xIn	Differential operate currents
Restrain Currents 0.00 0.00 0.00 xIn	Differential restrain currents
Mag Inrush Currents 0.00 0.00 0.00 xIn	Differential magnetising inrush currents (even harmonic content of operate currents but mainly 2 nd harmonic content)
[MISC METERS] --> press down <--	Start of miscellaneous meters
Status Inputs 1-16 ---- ---- ---- ----	Displays the state of DC status inputs 1 to 16 ¹
Status Inputs 17-27	Displays the state of DC status inputs 17 to 27 ¹

INSTRUMENT	DESCRIPTION

Output Relays 1-16 -----	Displays the state of output relays 1 to 16 ¹
Output Relays 17-29 -----	Displays the state of output relays 17 to 29 ¹
Time & Date 13/08/2002 10:16:11	Time and Date
Fault Records 0	Number of fault records stored
Event Records 0	Number of event records stored
Waveform Records 0	Number of waveform records stored

1) Only when fitted.

4 IEC 60870-5-103 Communications Information

4.1 IEC 60870-5-103 Semantics in monitor direction

FUN	INF	Description	GI	TYP	COT
60	1	IEC870 Active Com1	x	1	1,9
60	2	IEC870 Active Com2	x	1	1,9
60	3	Front Port OverRide	x	1	1,9

FUN	INF	Description	GI	TYP	COT
176	0	GI End	-	8	10
176	0	Time Synchronisation	-	6	8
176	2	Reset FCB	-	2	3
176	3	Reset CU	-	2	4
176	4	Start/Restart	-	2	5
176	22	Settings changed	-	1	1
176	23	Setting G1 selected	x	1	1,9
176	24	Setting G2 selected	x	1	1,9
176	25	Setting G3 selected	x	1	1,9
176	26	Setting G4 selected	x	1	1,9
176	27	Status Input 1	x	1	1,9
176	28	Status Input 2	x	1	1,9
176	29	Status Input 3	x	1	1,9
176	30	Status Input 4	x	1	1,9
176	36	Trip Circuit Fail	x	1	1,9
176	64	Start/Pick-up L1	x	2	1,9
176	65	Start/Pick-up L2	x	2	1,9
176	66	Start/Pick-up L3	x	2	1,9
176	67	Start/Pick-up N	x	2	1,9
176	68	General Trip	-	2	1
176	69	Trip L1	-	2	1
176	70	Trip L2	-	2	1
176	71	Trip L3	-	2	1
176	84	General Start/Pick-up	x	2	1,9
178	7	Biased Differential	-	2	1
178	8	Differential Highset	-	2	1
178	38	Earth Fault	-	2	1
178	85	Standby E/F Stage 1	-	2	1
178	86	Standby E/F Stage 2	-	2	1
178	70	Voltage Stage 1	-	2	1
178	71	Voltage Stage 2	-	2	1
178	72	Voltage Stage 3	-	2	1
178	73	Voltage Stage 4	-	2	1
178	74	Overfluxing Dtl Stage 1	-	2	1
178	75	Overfluxing Dtl Stage 2	-	2	1
178	76	Overfluxing Idmtl	-	2	1
178	90	Frequency Stage 1	-	2	1
178	91	Frequency Stage 2	-	2	1
178	92	Frequency Stage 3	-	2	1

FUN	INF	Description	GI	TYP	COT
178	93	Frequency Stage 4	-	2	1
178	124	Restricted Earth Fault 1	-	2	1
178	125	Restricted Earth Fault 2	-	2	1
178	126	Restricted Earth Fault 3	-	2	1
178	128	Cold Start	-	1	1
178	129	Warm Start	-	1	1
178	130	Re-Start	-	1	1
178	135	Trigger Storage	-	1	1
178	145	Status Input 5	x	1	1,9
178	146	Status Input 6	x	1	1,9
178	147	Status Input 7	x	1	1,9
178	148	Status Input 8	x	1	1,9
178	149	Status Input 9	x	1	1,9
178	150	Status Input 10	x	1	1,9
178	151	Status Input 11	x	1	1,9
178	152	Status Input 12	x	1	1,9
178	153	Status Input 13	x	1	1,9
178	154	Status Input 14	x	1	1,9
178	155	Status Input 15	x	1	1,9
178	156	Status Input 16	x	1	1,9
178	157	Status Input 17	x	1	1,9
178	158	Status Input 18	x	1	1,9
178	159	Status Input 19	x	1	1,9
178	160	Status Input 20	x	1	1,9
178	161	Status Input 21	x	1	1,9
178	162	Status Input 22	x	1	1,9
178	163	Status Input 23	x	1	1,9
178	164	Status Input 24	x	1	1,9
178	165	Status Input 25	x	1	1,9
178	166	Status Input 26	x	1	1,9
178	167	Status Input 27	x	1	1,9
178	181	Plant Control Relay 1	x	1	1,9
178	182	Plant Control Relay 2	x	1	1,9
178	183	Plant Control Relay 3	x	1	1,9
178	184	Plant Control Relay 4	x	1	1,9
178	185	Plant Control Relay 5	x	1	1,9
178	186	Plant Control Relay 6	x	1	1,9
178	187	Plant Control Relay 7	x	1	1,9
178	188	Plant Control Relay 8	x	1	1,9
178	189	Plant Control Relay 9	x	1	1,9
178	190	Plant Control Relay 10	x	1	1,9
178	191	Plant Control Relay 11	x	1	1,9
178	192	Plant Control Relay 12	x	1	1,9
178	193	Plant Control Relay 13	x	1	1,9
178	194	Plant Control Relay 14	x	1	1,9
178	195	Plant Control Relay 15	x	1	1,9
178	196	Plant Control Relay 16	x	1	1,9
178	197	Plant Control Relay 17	x	1	1,9

FUN	INF	Description	GI	TYP	COT
178	198	Plant Control Relay 18	x	1	1,9
178	199	Plant Control Relay 19	x	1	1,9
178	200	Plant Control Relay 20	x	1	1,9
178	201	Plant Control Relay 21	x	1	1,9
178	202	Plant Control Relay 22	x	1	1,9
178	203	Plant Control Relay 23	x	1	1,9
178	204	Plant Control Relay 24	x	1	1,9
178	205	Plant Control Relay 25	x	1	1,9
178	206	Plant Control Relay 26	x	1	1,9
178	207	Plant Control Relay 27	x	1	1,9
178	208	Plant Control Relay 29	x	1	1,9
178	209	Plant Control Relay 29	x	1	1,9
178	230	Measurand W1 I _{L1,2,3} W1 I _{L1} (2.4 x) W1 I _{L2} (2.4 x) W1 I _{L3} (2.4 x)	-	9	2
178	231	Measurand W2 I _{L1,2,3} W2 I _{L1} (2.4 x) W2 I _{L2} (2.4 x) W2 I _{L3} (2.4 x)	-	9	2
178	232	Measurand W3 I _{L1,2,3} W3 I _{L1} (2.4 x) W3 I _{L2} (2.4 x) W3 I _{L3} (2.4 x)	-	9	2
178	233	Measurand W4 I _{L1,2,3} W4 I _{L1} (2.4 x) W4 I _{L2} (2.4 x) W4 I _{L3} (2.4 x)	-	9	2
178	234	Measurand W5 I _{L1,2,3} W5 I _{L1} (2.4 x) W5 I _{L2} (2.4 x) W5 I _{L3} (2.4 x)	-	9	2

4.2 IEC 60870-5-103 Semantics in control direction

FUN	INF	Description	COM	TYP	COT
176	0	GI Initiation		7	9
176	0	Time Synchronisation		6	8
176	19	LED reset	ON	20	20
176	23	Settings Group 1 Select	ON	20	20
176	24	Settings Group 2 Select	ON	20	20
176	25	Settings Group 3 Select	ON	20	20
176	26	Settings Group 4 Select	ON	20	20
178	110	Settings Group 5 Select	ON	20	20
178	111	Settings Group 6 Select	ON	20	20
178	112	Settings Group 7 Select	ON	20	20
178	113	Settings Group 8 Select	ON	20	20

5 MODBUS Semantics

5.1 Coils (0xxxx)

Address	Description
00101	Settings Group 1
00102	Settings Group 2
00103	Settings Group 3
00104	Settings Group 4
00105	Settings Group 5
00106	Settings Group 6
00107	Settings Group 7
00108	Settings Group 8

5.2 Input Status (1xxxx)

Address	Description
10001	Status Input 1
10002	Status Input 2
10003	Status Input 3
10004	Status Input 4
10005	Status Input 5
10006	Status Input 6
10007	Status Input 7
10008	Status Input 8
10009	Status Input 9
10010	Status Input 10
10011	Status Input 11
10012	Status Input 12
10013	Status Input 13
10014	Status Input 14
10015	Status Input 15
10016	Status Input 16
10017	Status Input 17
10018	Status Input 18
10019	Status Input 19
10020	Status Input 20
10021	Status Input 21
10022	Status Input 22
10023	Status Input 23
10024	Status Input 24
10025	Status Input 25
10026	Status Input 26
10027	Status Input 27
10028	Status Input 28
10029	Status Input 29
10030	Status Input 30
10031	Status Input 31
10032	Status Input 32

Address	Description
10101	General Starter
10102	General Trip
10103	Phase A Starter
10104	Phase B Starter
10105	Phase C Starter
10106	Phase N Starter
10107	Phase A Trip
10108	Phase B Trip

Address	Description
10109	Phase C Trip
10110	Phase N Trip
10111	TCSAlarmOutput

Address	Description
10120	Relay Mode LOCAL
10121	Relay Mode REMOTE
10122	Relay Mode SERVICE

Address	Description
10200	87 Differential Phase A
10201	87 Differential Phase B
10202	87 Differential Phase C
10203	87HD Inhibit Phase A
10204	87HD Inhibit Phase B
10205	87HD Inhibit Phase C
10206	87 Trip
10207	87HS Differential Phase A
10208	87HS Differential Phase B
10209	87HS Differential Phase C
10210	87HS Trip

Address	Description
10220	87REF-1 Operated
10221	87REF-1 Starter
10222	87REF-1 Trip
10223	87REF-2 Operated
10224	87REF-2 Starter
10225	87REF-2 Trip
10226	87REF-3 Operated
10227	87REF-3 Starter
10228	87REF-3 Trip

Address	Description
10230	51G-1 Starter
10231	51G-1 Operated
10232	51G-1 Trip
10233	51G-2 Starter
10234	51G-2 Operated
10235	51G-2 Trip
10236	50G Starter
10237	50G Operated
10238	50G Trip

Address	Description
10240	U/V Guard Operated
10241	U/V Guard Starter
10242	U/V Guard Block
10243	27/59-1 Operated
10244	27/59-1 Starter
10245	27/59-1 Trip
10246	27/59-2 Operated
10247	27/59-2 Starter
10248	27/59-2 Trip
10249	27/59-3 Operated
10250	27/59-3 Starter
10251	27/59-3 Trip
10252	27/59-4 Operated
10253	27/59-4 Starter
10254	27/59-4 Trip

Address	Description
---------	-------------

Address	Description
10260	81-1 Operated
10261	81-1 Starter
10262	81-1 Trip
10263	81-2 Operated
10264	81-2 Starter
10265	81-2 Trip
10266	81-3 Operated
10267	81-3 Starter
10268	81-3 Trip
10269	81-4 Operated
10270	81-4 Starter
10271	81-4 Trip

Address	Description
10280	24DT-1 Operated
10281	24DT-1 Starter
10282	24DT-1 Trip
10283	24DT-2 Operated
10284	24DT-2 Starter
10285	24DT-2 Trip
10286	24IT Operated
10287	24IT Starter
10288	24IT Trip

5.3 Input Registers (3xxxx)

Address	Description	Format
30001	No. of Events In Store (See 434/TIR/15)	1 Register
30002	Latest Event Record (See 434/TIR/15)	8 Registers

Address	Description	Format
30010	Number of fault records	UINT16 ²
30012	Number of event records	UINT16 ²
30014	Number of waveform records	UINT16 ²
30016	Number of CPU re-starts	UINT16 ²
30018	Number of CPU warm starts	UINT16 ²

Address	Description	Format
30100	Operate Current Ia x In	FP_32BITS_3DP ¹
30102	Operate Current Ib x In	FP_32BITS_3DP ¹
30104	Operate Current Ic x In	FP_32BITS_3DP ¹
30106	Restrain Current Ia x In	FP_32BITS_3DP ¹
30108	Restrain Current Ib x In	FP_32BITS_3DP ¹
30110	Restrain Current Ic x In	FP_32BITS_3DP ¹
30112	Mag Inrush Current Ia x In	FP_32BITS_3DP ¹
30114	Mag Inrush Current Ib x In	FP_32BITS_3DP ¹
30115	Mag Inrush Current Ic x In	FP_32BITS_3DP ¹

Address	Description	Format
30200	87REF-1 Primary Current kA	FP_32BITS_3DP ¹
30202	87REF-1 Secondary Current A	FP_32BITS_3DP ¹
30204	87REF-1 Nominal Current xIn	FP_32BITS_3DP ¹
30206	87REF-2 Primary Current kA	FP_32BITS_3DP ¹
30208	87REF-2 Secondary Current A	FP_32BITS_3DP ¹
30210	87REF-2 Nominal Current xIn	FP_32BITS_3DP ¹
30212	87REF-3 Primary Current kA	FP_32BITS_3DP ¹
30214	87REF-3 Secondary Current A	FP_32BITS_3DP ¹
30216	87REF-3 Nominal Current xIn	FP_32BITS_3DP ¹

Address	Description	Format
30300	E/F Primary Current kA	FP_32BITS_3DP ¹

Address	Description	Format
30302	E/F Secondary Current kA	FP_32BITS_3DP ¹
30304	E/F Nominal Current kA	FP_32BITS_3DP ¹
30306	51G-1 Status	UINT16
30307	51G-1	UINT16

Address	Description	Format
30400	Primary Voltage kV	FP_32BITS_3DP ¹
30402	Secondary Voltage V	FP_32BITS_3DP ¹
30404	Nominal Voltage xVn	FP_32BITS_3DP ¹
30406	Frequency Hz	FP_32BITS_3DP ¹
30408	Nominal Frequency xfn	FP_32BITS_3DP ¹

Address	Description	Format
30500	V/f Voltage xVn	FP_32BITS_3DP ¹
30502	V/f Value xVn/fn	FP_32BITS_3DP ¹
30504	V/f IDMTL Status %	FP_32BITS_3DP ¹

Address	Description	Format
31100	W1 Primary Ia kA	FP_32BITS_3DP ¹
31102	W1 Primary Ib kA	FP_32BITS_3DP ¹
31104	W1 Primary Ic kA	FP_32BITS_3DP ¹
31106	W1 Sec'y Ia A	FP_32BITS_3DP ¹
31108	W1 Sec'y Ib A	FP_32BITS_3DP ¹
31110	W1 Sec'y Ic A	FP_32BITS_3DP ¹
31112	W1 Nom Ia xIn	FP_32BITS_3DP ¹
31114	W1 Nom Ib xIn	FP_32BITS_3DP ¹
31116	W1 Nom Ic xIn	FP_32BITS_3DP ¹
31118	W1 Line Ia xIn	FP_32BITS_3DP ¹
31120	W1 Line Ib xIn	FP_32BITS_3DP ¹
31122	W1 Line Ic xIn	FP_32BITS_3DP ¹
31124	W1 Relay Ia xIn	FP_32BITS_3DP ¹
31126	W1 Relay Ib xIn	FP_32BITS_3DP ¹
31128	W1 Relay Ic xIn	FP_32BITS_3DP ¹

Address	Description	Format
31200	W2 Primary Ia kA	FP_32BITS_3DP ¹
31202	W2 Primary Ib kA	FP_32BITS_3DP ¹
31204	W2 Primary Ic kA	FP_32BITS_3DP ¹
31206	W2 Sec'y Ia A	FP_32BITS_3DP ¹
31208	W2 Sec'y Ib A	FP_32BITS_3DP ¹
31210	W2 Sec'y Ic A	FP_32BITS_3DP ¹
31212	W2 Nom Ia xIn	FP_32BITS_3DP ¹
31214	W2 Nom Ib xIn	FP_32BITS_3DP ¹
31216	W2 Nom Ic xIn	FP_32BITS_3DP ¹
31218	W3 Line Ia xIn	FP_32BITS_3DP ¹
31220	W2 Line Ib xIn	FP_32BITS_3DP ¹
31222	W2 Line Ic xIn	FP_32BITS_3DP ¹
31224	W2 Relay Ia xIn	FP_32BITS_3DP ¹
31226	W2 Relay Ib xIn	FP_32BITS_3DP ¹
31228	W2 Relay Ic xIn	FP_32BITS_3DP ¹

Address	Description	Format
31300	W3 Primary Ia kA	FP_32BITS_3DP ¹
31302	W3 Primary Ib kA	FP_32BITS_3DP ¹
31304	W3 Primary Ic kA	FP_32BITS_3DP ¹
31306	W3 Sec'y Ia A	FP_32BITS_3DP ¹
31308	W3 Sec'y Ib A	FP_32BITS_3DP ¹
31310	W3 Sec'y Ic A	FP_32BITS_3DP ¹
31312	W3 Nom Ia xIn	FP_32BITS_3DP ¹
31314	W3 Nom Ib xIn	FP_32BITS_3DP ¹
31316	W3 Nom Ic xIn	FP_32BITS_3DP ¹
31318	W3 Line Ia xIn	FP_32BITS_3DP ¹
31320	W3 Line Ib xIn	FP_32BITS_3DP ¹

Address	Description	Format
31322	W3 Line Ic xIn	FP_32BITS_3DP ¹
31324	W3 Relay Ia xIn	FP_32BITS_3DP ¹
31326	W3 Relay Ib xIn	FP_32BITS_3DP ¹
31328	W3 Relay Ic xIn	FP_32BITS_3DP ¹

Address	Description	Format
31400	W4 Primary Ia kA	FP_32BITS_3DP ¹
31402	W4 Primary Ib kA	FP_32BITS_3DP ¹
31404	W4 Primary Ic kA	FP_32BITS_3DP ¹
31406	W4 Sec'y Ia A	FP_32BITS_3DP ¹
31408	W4 Sec'y Ib A	FP_32BITS_3DP ¹
31410	W4 Sec'y Ic A	FP_32BITS_3DP ¹
31412	W4 Nom Ia xIn	FP_32BITS_3DP ¹
31414	W4 Nom Ib xIn	FP_32BITS_3DP ¹
31416	W4 Nom Ic xIn	FP_32BITS_3DP ¹
31418	W4 Line Ia xIn	FP_32BITS_3DP ¹
31420	W4 Line Ib xIn	FP_32BITS_3DP ¹
31422	W4 Line Ic xIn	FP_32BITS_3DP ¹
31424	W4 Relay Ia xIn	FP_32BITS_3DP ¹
31426	W4 Relay Ib xIn	FP_32BITS_3DP ¹
31428	W4 Relay Ic xIn	FP_32BITS_3DP ¹

Address	Description	Format
31500	W5 Primary Ia kA	FP_32BITS_3DP ¹
31502	W5 Primary Ib kA	FP_32BITS_3DP ¹
31504	W5 Primary Ic kA	FP_32BITS_3DP ¹
31506	W5 Sec'y Ia A	FP_32BITS_3DP ¹
31508	W5 Sec'y Ib A	FP_32BITS_3DP ¹
31510	W5 Sec'y Ic A	FP_32BITS_3DP ¹
31512	W5 Nom Ia xIn	FP_32BITS_3DP ¹
31514	W5 Nom Ib xIn	FP_32BITS_3DP ¹
31516	W5 Nom Ic xIn	FP_32BITS_3DP ¹
31518	W5 Line Ia xIn	FP_32BITS_3DP ¹
31520	W5 Line Ib xIn	FP_32BITS_3DP ¹
31522	W5 Line Ic xIn	FP_32BITS_3DP ¹
31524	W5 Relay Ia xIn	FP_32BITS_3DP ¹
31526	W5 Relay Ib xIn	FP_32BITS_3DP ¹
31528	W5 Relay Ic xIn	FP_32BITS_3DP ¹

1) FP_32BITS_3DP: 2 registers - 32 bit fixed point, a 32 bit integer containing a value to 3 decimal places e.g. 50000 sent = 50.000

2) UINT16: 1 register - standard 16 bit unsigned integer

5.4 Holding Registers (4xxxx)

Address	Description	Format
40001	Time	

6 Reylogic Diagrams

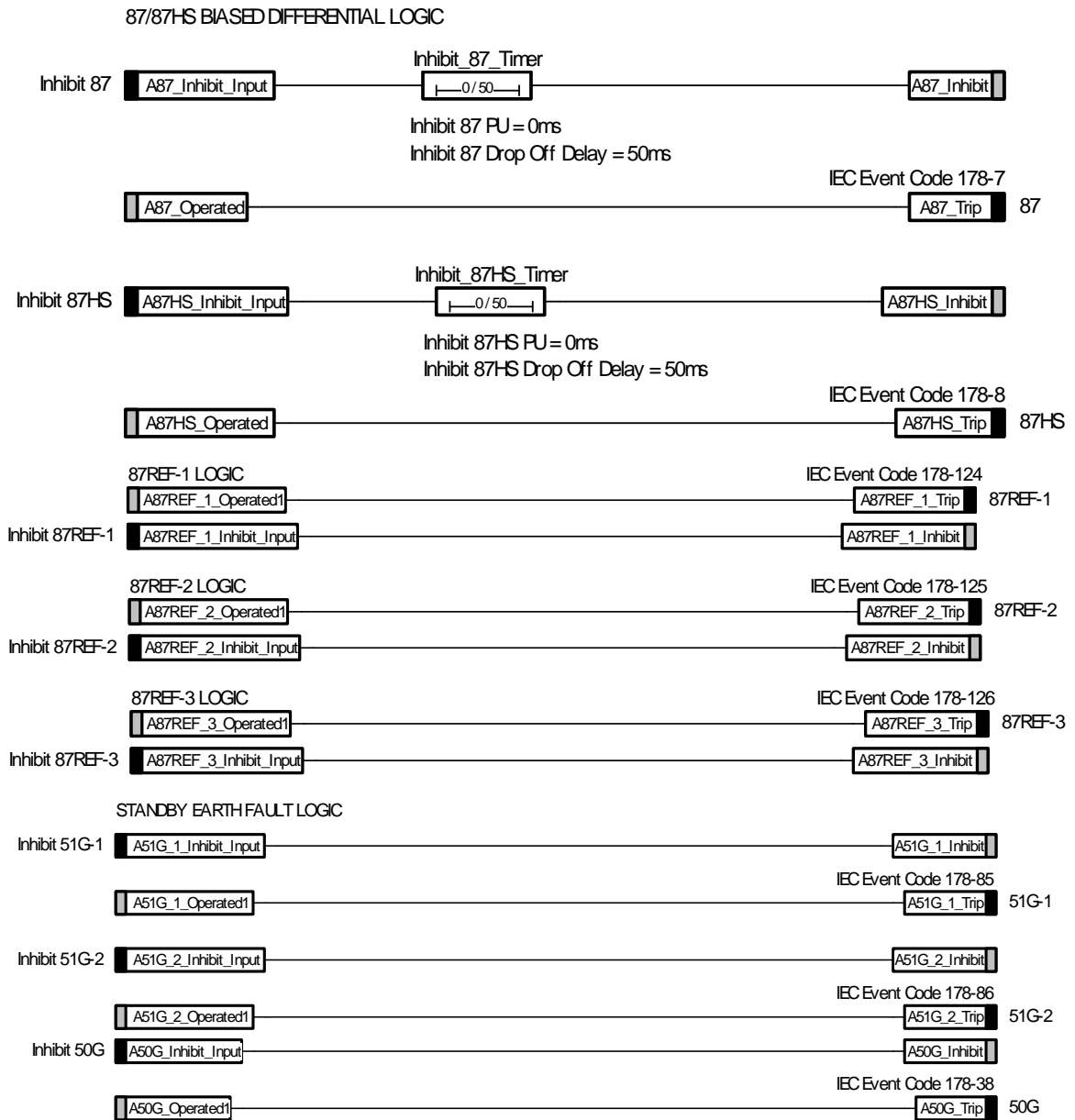

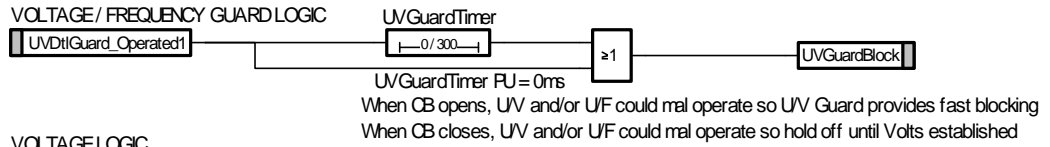

VOLTAGE LOGIC



FREQUENCY LOGIC



VOLTS/HERTZ OVERFLUXING LOGIC

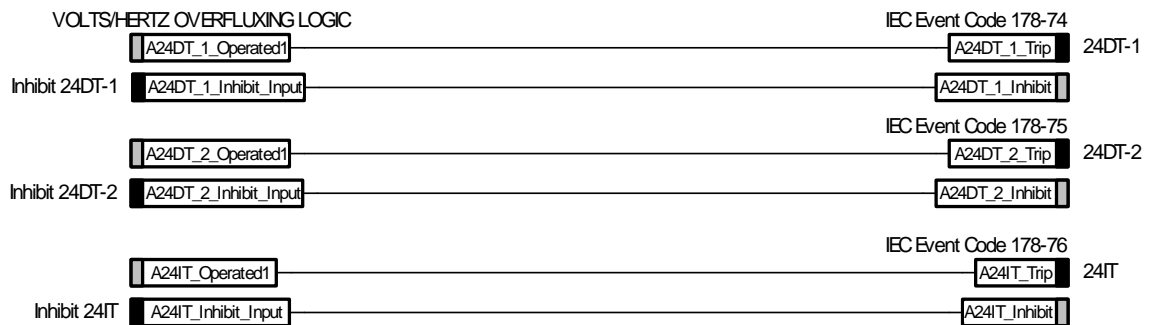

OVERALL PHASE SELECTION LOGIC

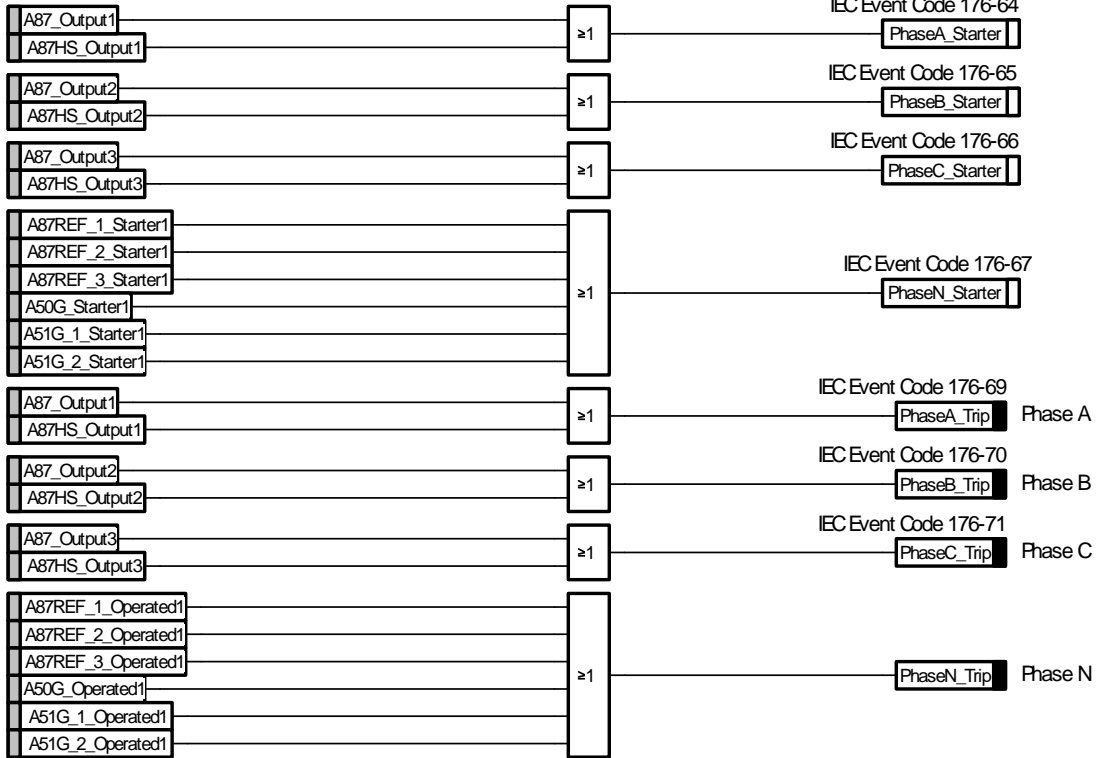

GENERAL STARTER LOGIC

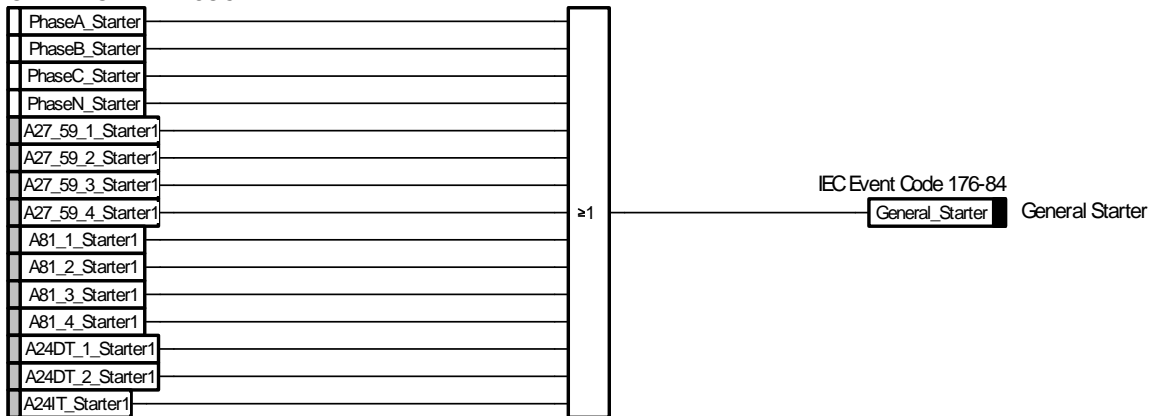

GENERAL TRIP LOGIC

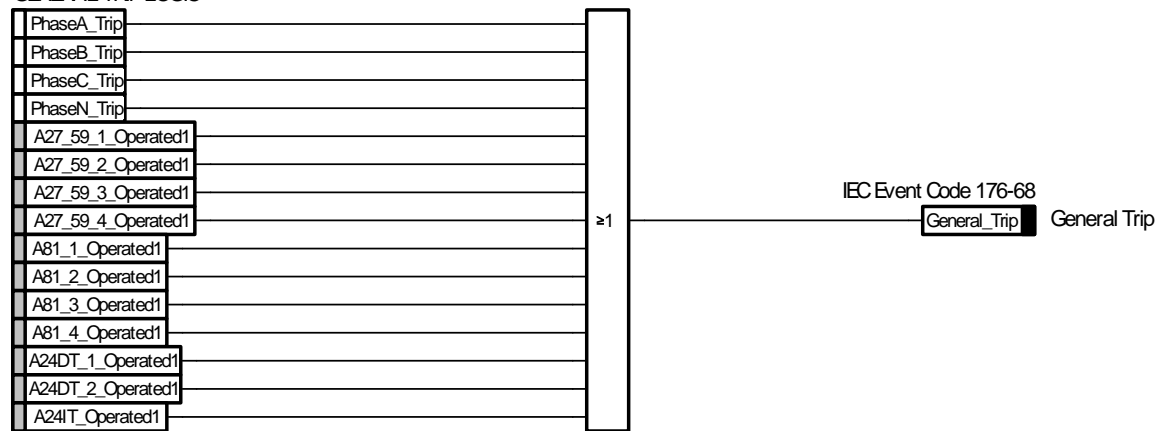

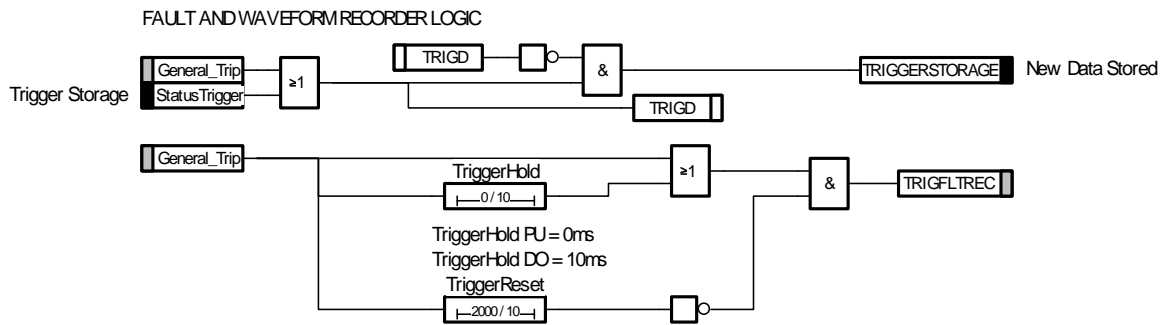
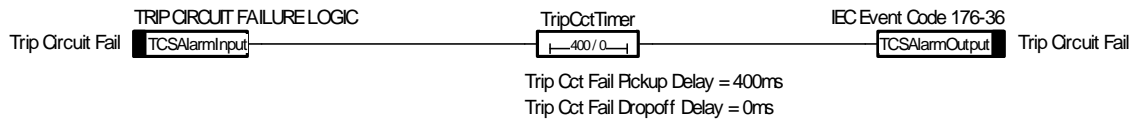

INPUTS TO SELECT A SETTING GROUP FROM A STATUS INPUT.



7 Label Inserts

7.1 5W E16 Case

	Duobias-M-208-5W	Duobias-M-208-5W	
	R14	R14	
	Left	Right	
	23.02.10	23.02.10	
1	GENERAL STARTER	(87) BIAS. DIFFERENTIAL	17
2	PHASE A	(87HS) DIFF. HIGHSET	18
3	PHASE B	(87REF) RESTRICTED E/F	19
4	PHASE C	(50G/51G) STANDBY E/F	20
5	RELAY 1	(27/59) VOLTAGE	21
6	RELAY 2	(81) FREQUENCY	22
7	RELAY 3	(24) OVERFLUXING	23
8		(74TC) TRIP CIRCUIT FAIL	24
9	AUX 1 I/P OPERATED	AUX 9 I/P OPERATED	25
10	AUX 2 I/P OPERATED	AUX 10 I/P OPERATED	26
11	AUX 3 I/P OPERATED	AUX 11 I/P OPERATED	27
12	AUX 4 I/P OPERATED		28
13	AUX 5 I/P OPERATED		29
14	AUX 6 I/P OPERATED		30
15	AUX 7 I/P OPERATED		31
16	AUX 8 I/P OPERATED		32